

Fan Filter Purification Unit– VFU Series

PRODUCT DESIGN :

VFU シリーズは、クリーンルーム内の乱流層と層流に使用されるモーターを内蔵したクリーンエアジェネレーターです。製品はマルチスピードレベルの設計であり、メンテナンスフリー、低振動、連続使用時の低騒音という利点があります。すべての VFU 製品は、国際保証に基づく ISO14644-1 に準拠したテストです。

VFU Series is clean air generator set with motor inside which is used in the turbulent layer and laminar flow in clean room. Product are design of multi-speed levels, which has advantages of maintenance free, low vibration and low noise when continuous use. All of VFU product are test according of ISO14644-1 based on international guarantee.

PRODUCT DESCRIPTION :

- Multi-speed levels adjustment
- Long-life span, low noise and low vibration.
- Compact design easy to installation.
- Super Thin FFU and Direct current motor type are available.

APPLICATIONS :

HEPA フィルターと併用して、半導体産業、病院、クリーンベンチ、バイオセーフティゾーン、クリーンルームなどに適した加圧とクリーンエアを生成します。

Using with HEPA filter to generate pressurization and clean air, suitable for semiconductor industry, hospitals, clean bench, Bio safety zone, clean room and other.

SPECIFICATION :

MODEL	VFU / 600 ~ 1200	FAN MOTOR	Centrifugal fan
DIMENSION	24 x 24 / 24 x 48 Inch / Custom size	POWER SUPPLY	EC / AC / DC on request
AIR CAPACITY	600 ~ 1200 CMH	NOISE LEVEL	Less than 63 dB (1m. below HEPA)
VIBRATION	0.2 ~ 0.7 mm/s	FAN SPEED	3 Level speed control manually / Group control

FILTER DESCRIPTION :

PRE FILTER	Synthetic prefilter optional on request
HEPA FILTER	High efficiency ultra fine fiberglass media with hot-melt separator, H14 Class 99.999% on 0.3 μm
FRAME FILTER	Galvanized steel / High quality anodized aluminum
FILTER TESTING	Individual test certificate from production factory



FILTER CLASS :



FEATURES :



Vilberg

THE ULTIMATE OF AIR FILTERS

100/2 LEABKLONGMON RD, TUB YAO, LADKRABANG, BANGKOK 10520 THAILAND

TEL. (+662)-360-6602, (+6686)-500-3797, (+6687)-054-4416 FAX. (+662)-360-6603

EMAIL : info@filtermatch2002.com , filtermatch2002@hotmail.com WEBSITE : www.filtermatch2002.com



ISO 9001:2015
CERTIFY NO. HK03/0251

ISO 14001:2015
NO. HK03/60492

UL Certified
R26298-20181108

Fan Filter Purification Unit– VFU Series

PRODUCT PARAMETER :

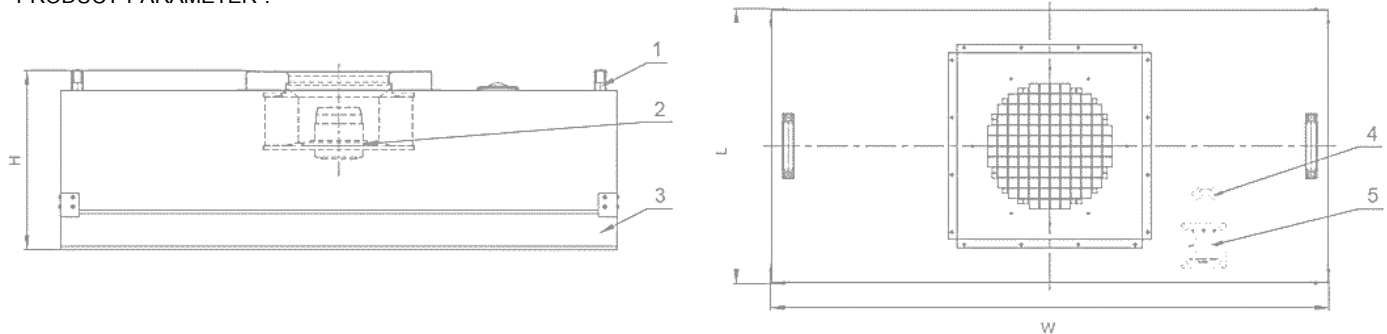

1.) HANDLE	Plastic extrude molding
2.) FAN MOTOR	Centrifugal fan filter with galvanize frame
3.) HEPA FILTER	High efficiency ultra fine fiberglass media with hot-melt separator, H14 Class 99.999% on 0.3 μm
4.) POWER CONNECTOR	EC / AC and DC power supply
5.) CONTROLER SWITCH	Knob switch / Panel bottom manually switch / Group control by computer

SPECIFICATION :

MODEL	VFU / 600	VFU / 1200
DIMENSION	24 x 24 Inch	24 x 48 Inch
MODULE ACTUAL SIZE	615 x 615 x 375 mm.	615 x 1225 x 375 mm.
AIR CHAMBER MATERIAL	GI / AI / SUS	GI / AI / SUS
AIR CAPACITY	550 ~ 600 CMH	1100 ~ 1200 CMH
AIR VELOCITY	0.35 ~ 0.55 m/s	0.35 ~ 0.55 m/s
TOTAL PRESSURE	174 Pa	195 Pa
POWER CONSUMPTION	85 W	115 W
WEIGHT	25 kg.	40 kg.
NOISE dB (1m below HEPA filter)	55 – 63 dB	55 – 63 dB
VIBRATION	0.2 ~ 0.7 mm/s	0.2 ~ 0.7 mm/s
POWER SUPPLY	220V 1PH 50/60Hz (330V 3PH 50/60Hz)	220V 1PH 50/60Hz (330V 3PH 50/60Hz)
CONTROL MODE	3 Level speed adjustable manually / Group control	3 Level speed adjustable manually / Group control
OPTIONS	Different pressure test port / Pressure alarm device	Different pressure test port / Pressure alarm device
FILTER DIMENSION	610 x 610 x 69 mm.	610 x 1220 x 69 mm.
EFFICIENCY	MINIPLEAT HEPA FILTER 99.995% (H14)	MINIPLEAT HEPA FILTER 99.995% (H14)
FILTER MEDIA	Fiberglass media / PTFE low pressure media	Fiberglass media / PTFE low pressure media
FILTER OPTIONS	Pre-filter G3 / G4	Pre-filter G3 / G4

*Special size / custom size on request 30 – 45 Days

Vilberg
THE ULTIMATE OF AIR FILTERS

100/2 LEABKLONGMON RD, TUB YAO, LADKRABANG, BANGKOK 10520 THAILAND

TEL. (+662)-360-6602, (+6686)-500-3797, (+6687)-054-4416 FAX. (+662)-360-6603

EMAIL : info@filtermatch2002.com , filtermatch2002@hotmail.com WEBSITE : www.filtermatch2002.com



ISO 9001:2015
CERTIFY NO. HK03/0251

ISO 14001:2015
NO. HK03/60492

UL Certified
R26298-20181108